

SMP TILTROTATOR ST10

Machines 6 - 10 tonnes

ST10

The SMP Tiltrotator improves flexibility and makes the machine more effective. It has a grease lubricated gear housing, constant rotation and 40° tilt in all directions. The tiltrotator can be mounted onto the existing quick coupler or directly onto the excavator arm. Easy maneuvering of the tilt rotator with joystick thumb rollers or rocker switch, allows the operator to easily and effectively perform advanced and precision work without having to move the machine. This also makes the work environment safer for both the operator and those working near the machine.

Available with double-acting cylinders or single-acting telescopic cylinders for tilting.

ST10 can be adapted for most machines in the size range and is available with most types of quick coupler systems and with a direct mounted upper/lower section.



NEW FEATURES OF THE SMP TILTROTATOR GENERATION 4

Maintenance and productivity

- Improved central lubrication which can also be connected to the machine's central lubrication system.
- Lubrication free bearings which reduce the amount of lubrication points by approximately 50%.

For the user

- We offer a new system based on the CAN Bus platform. This gives a whole new user interface.
- The system is easy and quick to install.
- The operating handle is ergonomically designed with different degrees of functionality.

Safety

- There are integrated load holding valves in the tilt cylinder.
- Attachment bracket with spring locks are used for double the safety in the event of a loss of pressure.

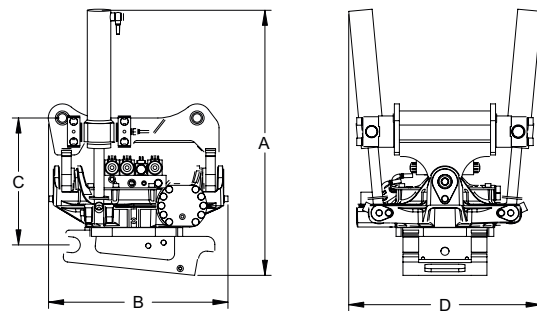

TECHNICAL SPECIFICATIONS SWINGOTILT ST10

Infinite rotation 360°

Tilting 2 x 40°

12/24V DC

Grease filled gear housing

Control system

MACST / Pro / P

Valve system

TS-TXXSC

Open Source Solution

Pro OS

Mounting	S45 / S50	SMP3
Approx weight (kg)	260	260
Dimensions A / B / C / D	870 / 590 / 430 / 600	890 / 640 / 480 / 600
Tilt angle	2 x 40°	2 x 40°
Rotation	Infinite 360°	Infinite 360°
Oil flow Min / Max	30 / 60 (*80) L/min	30 / 60 (*80) L/min
Operating pressure Min / Max	18 / 21 Mpa	18 / 21 Mpa
Tilt torque at 21 Mpa	20,6 / 25,3 kNm	20,6 / 25,3 kNm
Rotation speed	7 sec / rotation	7 sec / rotation
Torque	5000 Nm	5000 Nm

Weights can vary depending on design of product. *With Macs ST.