

KOMATSU

WA100M-8

EU Stage IV Engine

WHEEL LOADER

PRELIMINARY



WA100

ENGINE POWER

69,8 kW / 93,6 HP @ 2.000 rpm

OPERATING WEIGHT

6.925 - 7.230 kg

BUCKET CAPACITY

1,05 - 1,8 m³

Walk-Around

W/A100M-8



ENHANCED FUEL EFFICIENCY AND ENVIRONMENTAL PERFORMANCE

Powerful and Environmentally Friendly

- NEW** • EU Stage IV engine
- NEW** • Greater engine power
- NEW** • Increased capacity for the standard bucket
- NEW** • Faster travel speed
- Highly efficient hydrostatic drive line
- Low operating costs

First-Class Comfort

- NEW** • Large multifunctional monitor
- NEW** • Improved, ergonomic control elements
- NEW** • PPC multi-function lever with optional electronic control for 3rd and 4th spool (EPC)
- Air conditioner (optional)
- Electronic Controlled Suspension System (ECSS) (optional)

Total versatility

- NEW** • 3rd and 4th hydraulic circuits at machine rear (optional)
- NEW** • High flow version (optional)
- NEW** • Height-adjustable trailer hitches (optional)
- Easy Fork (EF) kinematic for parallel movement during fork application

Productive and safe

- NEW** • Improved rear visibility, complies with ISO 5006
- Highest payloads and tipping loads
- Superior breakout force
- Low centre of gravity

KOMTRAX

- Komatsu Wireless Monitoring System
- 3G mobile communications
- Integrated communication antenna
- Increased operational data and fuel savings



Specifications

ENGINE

Model	Komatsu SAA4D94LE-3
Type	Common rail direct injection, water-cooled, emissionised, turbocharged, after-cooled diesel
Engine power	
at rated engine speed	2.000 rpm
ISO 14396	69,8 kW / 93,6 HP
Max. torque/engine speed	394 Nm/1.475 rpm
No. of cylinders	4
Bore × stroke	94 × 110 mm
Displacement	3,05 l
Air-filter type	Dry air filter with pre-filter and safety cartridge

TRANSMISSION

Drive system	Hydrostatic transmission
Hydrostatic pump	1 variable piston pump
Hydrostatic motor	1 variable piston motor
Speed ranges (forwards/backwards)	2/2
Max. travel speeds (forwards/backwards) 20 km/h version	
1. speed range	0 - 6,0 km/h
2. speed range	0 - 20,0 km/h
Creep	0 - 10,0 km/h
Max. travel speeds (forwards/backwards) 40 km/h version	
1. speed range	0 - 15 km/h
2. speed range	0 - 40 km/h
Creep	0 - 10 km/h

CHASSIS AND TYRES

Type	Low build rear axle oscillation for optimum stability and for best performance in earthmoving applications
System	4-wheel drive
Axles	Planetary rigid axles with automatic limited slip differentials in both axles 100% locking differentials as option
Oscillation	Rear axle oscillation for optimum stability, oscillation angle 10°
Tyres	455/70 R20 (standard)

SERVICE REFILL CAPACITIES

Cooling system	22,3 l
Fuel tank	110 l
Engine oil	10,5 l
Hydraulic system	50 l
Front axle	9,1 l
Rear axle	9,1 l
Transfer (20 km/h / 40 km/h)	1,3 / 1,6 l
AdBlue® tank	20 l

BRAKES

Operating brakes	Combined inch brake pedal actuates maintenance free, wet multi-disc type brakes in the front axle Self-braking via the hydrostatic drive
Parking brake	Integrated wet multi-disc type brake

HYDRAULIC SYSTEM

System	Open hydraulic system
Working pressure (max.)	270 bar
Maximum pump flow	75 l/min
Option	120 l/min
No. of boom/bucket cylinders	2/1
Type	Double-action
Bore diameter × stroke	
Boom cylinder	80 × 714 mm
Bucket cylinder	100 × 476 mm
Hydraulic control lever	Multifunction lever
Hydraulic cycle with rated load bucket filling	
Raise time	5,7 s
Lowering time (empty)	3,7 s
Dumping time	1,3 s

STEERING SYSTEM

System	Articulated frame steering
Type	Hydraulic
Steering angle to either side	42°
Steering pump	Gear pump
Working pressure	175 bar
No. of steering cylinders	2
Type	Double-action
Bore diameter × stroke	60 × 369 mm
Smallest turn (outer edge of tyre 455/70 R20)	4.130 mm

CABIN

Cabin in conformity with ISO 3471 with ROPS (roll over protective structure) in conformity with SAE J1040c and FOPS (falling object protective structure) in conformity with ISO 3449. The pressurised cabin is mounted upon hydrobearings and is noise dampened. Tiltable for best servicing access.

ENVIRONMENT

Engine emissions	Fully complies with EU Stage IV exhaust emission regulations
Noise levels	Noise levels (external/internal) fully comply with 2000/14/EC Stage 2 and 98/37/EC
Vibration levels (EN 12096:1997)	
Hand/arm	≤ 2,5 m/s ² (uncertainty K = 0,75 m/s ²)
Body	≤ 0,5 m/s ² (uncertainty K = 0,53 m/s ²)
Contains fluorinated greenhouse gas HFC-134a (GWP 1430). Quantity of gas 1,2 kg, CO ₂ equivalent 1,72 t.	

Dimensions & Performance Figures

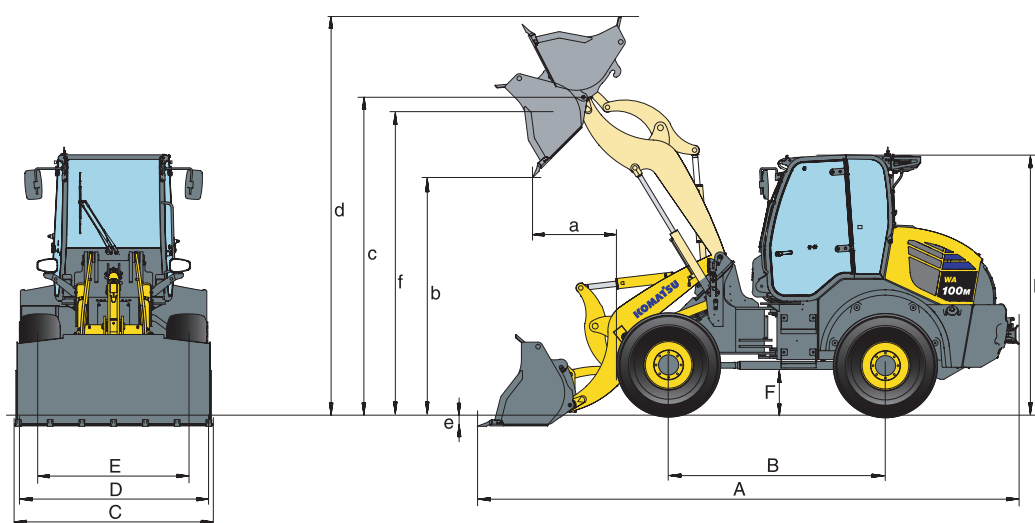

MEASUREMENTS AND WORKING SPECIFICATIONS

		Universal				Light materials	4-in-1
		w. teeth	w/o teeth	w. teeth	w/o teeth	w/o teeth	w. teeth
Bucket capacity (heaped, ISO 7546)	m³	1,3	1,3	1,4	1,4	1,6	1,05
Sales code		C61	C11	C14	C12	C13	C16
Material density	t/m ³	1,8	1,8	1,5	1,5	1,25	1,8
Bucket weight	kg	428	402	452	427	461	695
Static tipping load, straight	kg	6.080	6.200	6.220	6.225	5.850	5.850
Static tipping load, 40° articulated	kg	5.195	5.285	5.300	5.325	4.975	5.205
Break-out force hydraulic	kN	60,4	60,4	71,7	71,7	76,4	62,6
Lifting capability hydr. at ground level	kN	59,8	59,8	69,6	69,6	75,3	61,8
Operating weight	kg	7.090	7.065	7.100	7.075	7.125	7.360
Turning radius at corner of tyres	mm	4.125	4.125	4.125	4.125	4.125	4.125
Turning radius at bucket edge	mm	4.655	4.655	4.660	4.660	4.670	4.670
a Reach at 45°	mm	940	845	1.035	945	965	960
b Dump height at 45°	mm	2.635	2.655	2.405	2.305	2.480	2.545
c Hinge pin height	mm	3.520	3.520	3.505	3.505	3.520	3.520
d Height top edge of bucket	mm	4.420	4.420	4.420	4.420	4.470	4.415
e Digging depth	mm	130	130	130	130	125	85
f Max. loading height at 45°	mm	3.110	3.110	3.070	3.070	3.025	3.045
A Overall length, bucket grounded	mm	6.000	5.865	6.145	6.005	6.105	6.015
B Wheelbase	mm	2.400	2.400	2.400	2.400	2.400	2.400
C Bucket width	mm	2.300	2.300	2.200	2.200	2.200	2.200
D Width over tyres	mm	2.080	2.080	2.080	2.080	2.080	2.080
E Track width	mm	1.635	1.635	1.635	1.635	1.635	1.635
F Ground clearance	mm	390	390	390	390	390	390
H Overall height	mm	2.885	2.885	2.885	2.885	2.885	2.885

All measurements with tyres 455/70 R20

Dimensions & Performance Figures

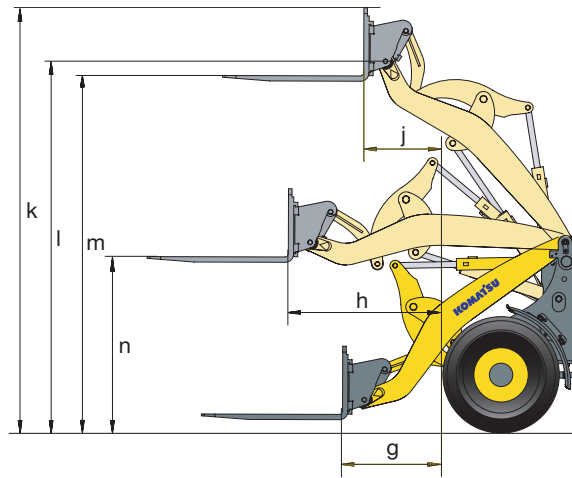

PERFORMANCE FIGURES WITH FORK TINES

Sales code	C24	
Fork tine type	FEM IIA	
Fork tine length	mm	1.200
g Max. reach at ground level	mm	850
h Max. reach	mm	1.380
j Max. reach at max. stacking height	mm	565
k Max. height fork-carrier	mm	4.000
l Hinge pin height	mm	3.525
m Max. stacking height	mm	3.320
n Height of forks at maximum reach	mm	1.540
Max. tipping load, straight	kg	4.515
Max. tipping load, articulated	kg	3.920
Max. payload as per EN 474-3, 80%	kg	3.136
Max. payload as per EN 474-3, 60%	kg	2.352
Weight in working order with fork tines	kg	6.980



Standard and Optional Equipment

ENGINE

Komatsu SAA4D94LE-3 turbocharged common rail direct injection diesel engine	●
EU Stage IV compliant	●
Alternator 150 A/12 V	●
Starter motor 3,0 kW/12 V	●
Battery 100 Ah/12 V	●

TRANSMISSION AND BRAKES

Combined inch/brake pedal	●
Creeping function (40 km/h version)	○
Creeping function (20 km/h version)	○
20 km/h limited hydrostatic driveline	○
40 km/h limited hydrostatic driveline	○

CHASSIS AND TYRES

Heavy-duty axles	●
LSD-differential front and rear	●
100% manual locking differentials front and rear	○
Various tyre types and sizes on request	○

HYDRAULIC SYSTEM

3-spool main control valve	●
PPC multi-function lever	●
Hydraulic quick-coupler	●
4-spool main control valve	○
Electronic control for 3rd spool (EPC)	○
Electronic control for 4th spool (EPC)	○
Loader control with return-to-dig	○
Auto-inch valve	○
Biodegradable oil for hydraulic system	○
3rd hydraulic function, rear	○
4th hydraulic function, rear	○
High flow version	○

LIGHTING SYSTEM

Halogen headlights	●
Reversing lights	●
Additional lights front and rear	○
LED headlights	○
Optical back-up alarm (strobe light)	○

CABIN

Spacious double door driver's cab to DIN/ISO with heating	●
Tilting cab	●
ROPS/FOPS frame according to SAE	●
All-round tinted glazing	●
Heated rear window	●
Rear window wiper	●
Sun visor	●
Adjustable steering column	●
Suspended seat	●
Seat belt (EU standard)	●
Wrist rest with integrated small storage box	●
Large storage box at left hand side	●
Multi-function colour monitor with Equipment Management and Monitoring System (EMMS) and efficiency guidance	●
12 Volt power supply	●
Front window wiper with intermittent feature	●
Adjustable high comfort air suspension seat	○
Air conditioning	○
Hydraulic dump control for trailer	○
Radio	○
Sun reflection decal for cab/canopy roof	○

SAFETY EQUIPMENT

Emergency steering system	●
Back-up alarm	●
Horn	●
Emergency engine stop switch	●
Seat belt caution indicator	●
Battery main switch	●
Beacon light	○
Immobiliser	○
Immobiliser with master key	○
Anti-drop valve	○
Fire extinguisher	○

OTHER EQUIPMENT

Z-bar boom (parallel movement when using dedicated fork tines)	●
Counterweight	●
Towing device	●
Electronically controlled suspension system load stabilizer (ECSS)	○
Special custom colour	○
Bucket level indicator	○
Additional counterweight 185 kg	○
Ball-type hitch (acc. to German road regulation StVZO)	○
Automatic hitch (acc. to German road regulation StVZO)	○
High-adjustable hitch (acc. to German road regulation StVZO)	○

SERVICE AND MAINTENANCE

KOMTRAX – Komatsu wireless monitoring system	●
Tool-set	●
Radiator fan with reversing function	○
Automatic central lubrication	○

ATTACHMENTS

Bucket with or without teeth	○
4-in-1 bucket	○
Light material buckets	○
Fork carrier and tines	○
Cutting edge guard	○

The WA100M-8 is equipped in accordance with the safety regulations of the machinery guidelines 89/392 EWG ff and EN474.

- standard equipment
- optional equipment

Your Komatsu partner:

KOMATSU

Komatsu Europe International N.V.
 Mechelsesteenweg 586
 B-1800 VILVOORDE (BELGIUM)
 Tel. +32-2-255 24 11
 Fax +32-2-252 19 81
www.komatsu.eu

VENSS06801P 08/2018

KOMATSU is a trademark of Komatsu Ltd. Japan.