



CONSTRUCTION TECHNOLOGY

TILTROTATOR • ROTOBOX • XTRATILT

BETTER WITHOUT
CYLINDER



The best for every challenge

NO LIMITS TO INDIVIDUALITY

Each application is different and requires different tools as well. For this purpose, HKS has the largest market range of turning and swiveling tools, which ideally covers every application. Whether only simple pivoting or rotating, or both at once.

We develop, design and produce according to your ideas and thus achieve the best for you and your excavator.

Our design team adapts each product individually to your excavator, so the kinematics remain in the best possible way and the volume of each bucket can be utilized maximally.

Convince yourself of our solutions, likewise as well directly on site.

Trust in HKS with over 45 years experience in the field of hydraulic and pneumatic rotary actuators and fifteen years of successful products for the Construction Technology segment.

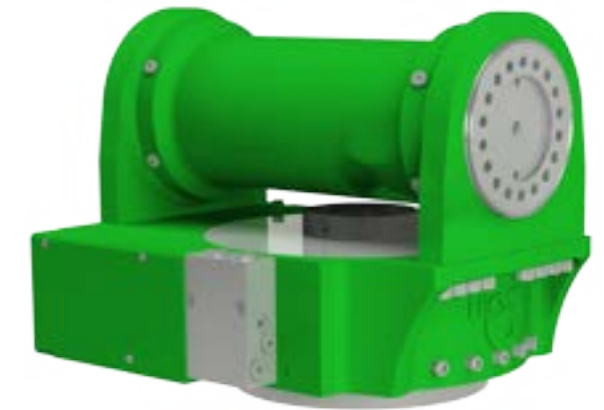

TILTROTATOR **TR**

- › Best possible accessibility of operating positions thanks to simultaneous tilting and rotating
- › Spatial positioning enables previously impossible areas of application for your attachments

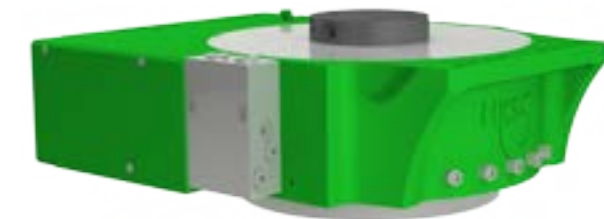

ROTOBOX **RB**

- › Improved accessibility of operating positions thanks to rotating
- › Immediate changeover from backhoe to face bucket by means of simple rotation

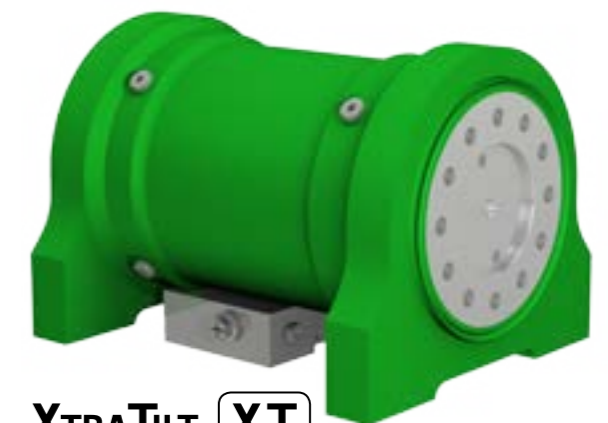

XTRATILT **XT**

- › Improved accessibility of operating positions by tilting
- › Easy handling of works on embankments



TILTROTATOR TR



Combination
With adapter to dipperstick connection and quick coupler



Sandwich-Solution
With quick-coupler adapter and quick coupler

Further intermediate tilt angles available upon request.

Made to Measure -
for any application



ROTOBOX RB



Combination
With adapter to dipperstick connection and quick coupler



Sandwich-Solution
With quick-coupler adapter and quick coupler

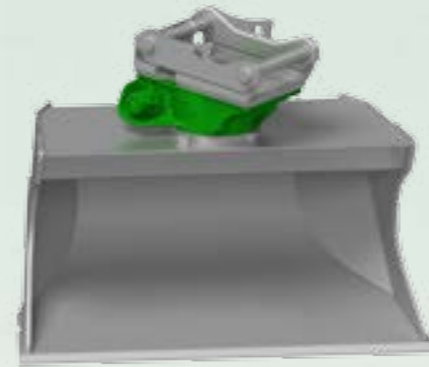

Direct-Connection
For connecting directly to the bucket

Discover the broad diversity of HKS Construction Technology products, and use them **to boost your productivity.**



XTRATILT XT

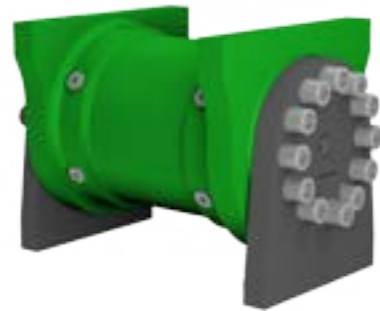

With Lugs
With lugs for direct connection. Oil feedthrough an optional extra.



Combination
With permanent shaft connection and quick coupler



Sandwich-Solution
With quick-coupler adapter and quick coupler



Direct-Connection
For connecting directly to the bucket

Further intermediate tilt angles available upon request.

Variations over Combinations

Alternative:
Welded connection from adapter to dipperstick connection and XtraTilt for a more compact overall height.



All facts at a glance:

- › Adapter board compatible with all quick couplers
- › Dipperstick connection individually adapted for all carrier devices
- › Can be used on all attachments

Legend:
L = lugs
C = combination (adapter to dipperstick connection/quick coupler adapter and quick coupler)

	XTRATILT	XTRATILT L-version	XTRATILT K-version		ROTOBOX	ROTOBOX K-version		TILTROTATOR	TILTROTATOR K-version	
	As a stand-alone device	With lugs for direct connection to the bucket	With adapter to dipperstick connection and quick coupler	With quick-coupler adapter and quick coupler	As a stand-alone device	With adapter to dipperstick connection and quick coupler	With quick-coupler adapter and quick coupler	As a stand-alone device	With adapter to dipperstick connection and quick coupler	With quick-coupler adapter and quick coupler
Adapter to dipperstick connection (optional) Compatible with all excavators up to 100 t Also available as a welded version or with a quick coupler adapter										
HKS XtraTilt BETTER WITHOUT CYLINDER 54 models in 18 sizes up to 100 t Tilt angle: 100°, 140° or 180° Holding torque of up to 165,000 Nm										
Oil feedthrough (optional) two sizes - standard and XL Flow rate of up to 500 l/min 5 flow rate channels Optional power feedthrough										
HKS RotoBox In 7 sizes from 1 t to 55 t Torque of up to 12,000 Nm Up to 8 rotations/min (with adapter board)										
Quick coupler (optional) Compatible with all mechanical and hydraulic quick couplers										

Special solutions available on request. Just contact us.

Exact made-to-measure product for your excavator.
Higher bucket volume. by preservation of the kinematics.

new

The optimized RotoBox decreases construction height,
width and weight in comparison to the previous model.



110°



8

Further intermediate tilt angles available upon request.

Videos from fields of application to find under:
www.hks-partner.com

TILTROTATOR

Form follows Function

- › 2 x 55° simultaneous tilting and endless rotating
- › One TiltRotator for all attachments
- › You can achieve outrageous operating positions, also because of the opportunity to built-in narrow tools

The TiltRotator enables you to tilt your attachment $\pm 55^\circ$ (on request even higher) in both directions and rotate endlessly at the same time. These two functions provide three-dimensional positioning easily and accurately, increasing your efficiency and productivity.

With its compact and robust tilt unit, the TiltRotator is an incomparable alternative to conventional wider cylinder variants, which are prone to faults. An optimised XtraTilt with extended torque and reduced overall height is used for the TiltRotator.

Details

- › Standard tilt angle of 2 x 55° (even higher on request)
- › Holding torque of up to 90,000 Nm
- › Torque of up to 43,000 Nm
- › In 10 models for a carrier device weight of up to 55 t.
- › Up to 8 rotations per minute
- › Modular system design

Less Consumption - More Performance

Your product advantages

More efficient machine utilisation rate

- › Optimized working width and therefore narrower and lighter working tools can be attached, which decreases the entire weight and excavation
- › Extended radius of action in a stationary position
- › Larger tilt angle
- › Attachment mounting with quick coupler from any stationary position of the carrier device
- › Increases the mobility of your attachments optimises their range of operation

Reduces construction site costs

- › Less re-adjustment of the vehicles saves time and fuel, reduces wear and tear to the machine
- › Fewer maintenance requirements and less lubrication reduce downtimes
- › Increased machine utilisation rates of up to 40% shorten the amortisation period
- › Easy retrofitting of existing machinery thanks to compatibility with all quick couplers and carrier devices
- › Maximum accessibility and precise maintenance of the selected operating positions
- › More orders can be completed during the same amount of time
- › Indispensable for gardening and landscaping, drainage channel construction and civil engineering



Exact Positioning - without Expenditure



Conventional models

- Projecting, disturbing cylinders. Problems with excavating
- Damage to the cylinders caused by soil, stones and dirt
- Continuous re-lubrication/ greasing of the cylinder bearing necessary
- Bearings susceptible to maintenance
- Restricted tilt angle and angle-dependent tilt torque

HKS TILTROTATOR BETTER WITHOUT CYLINDER

- Narrower width, compact, robust, insensitive to dirt, powerful
- Greater accessibility thanks to greater tilt angle
- Lower maintenance costs due to longer service intervals
- Maintenance-free, strong friction bearings
- Constant tilt torque, regardless of tilt angle

Simplified representation

Accessibility of operating positions

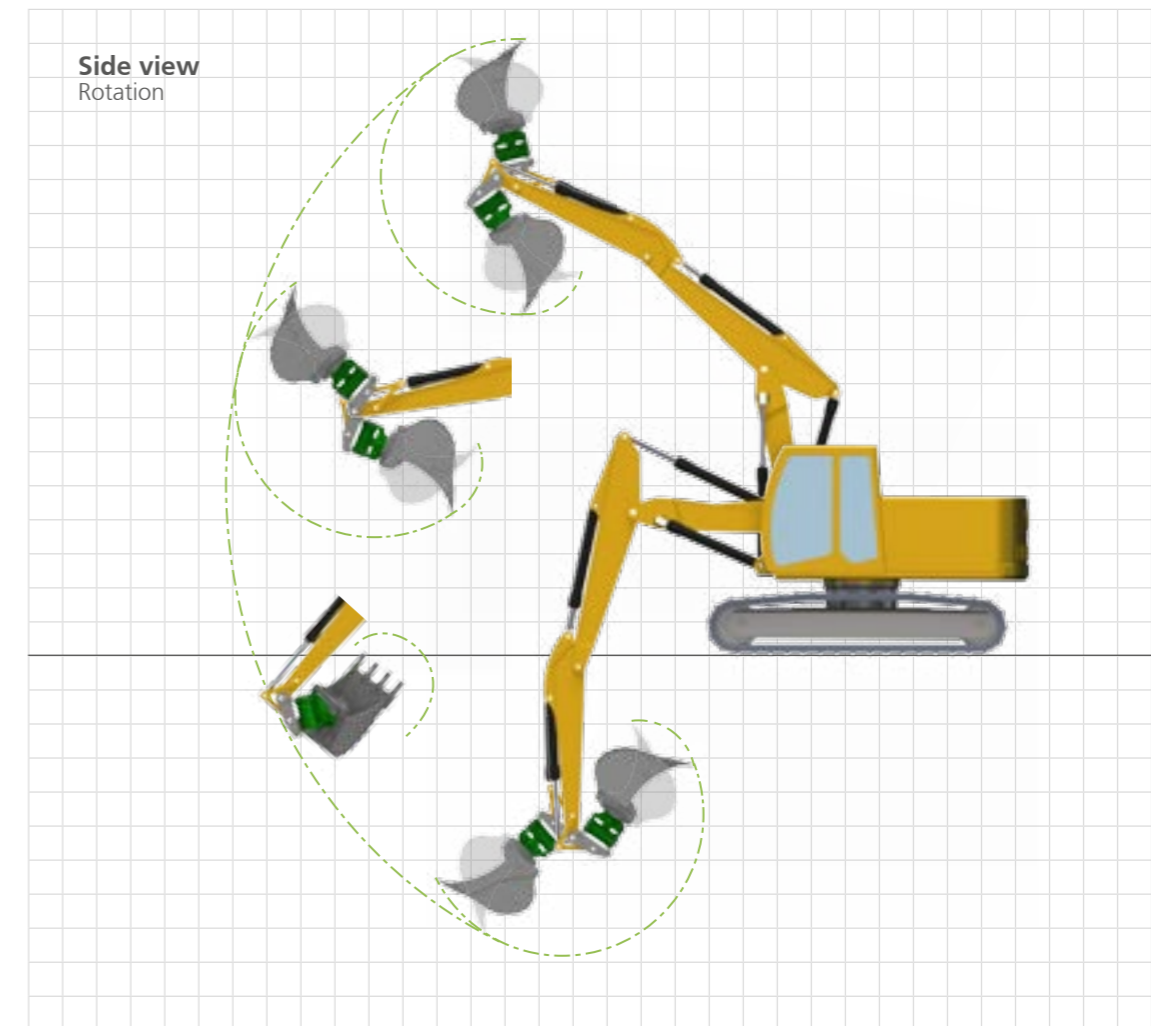
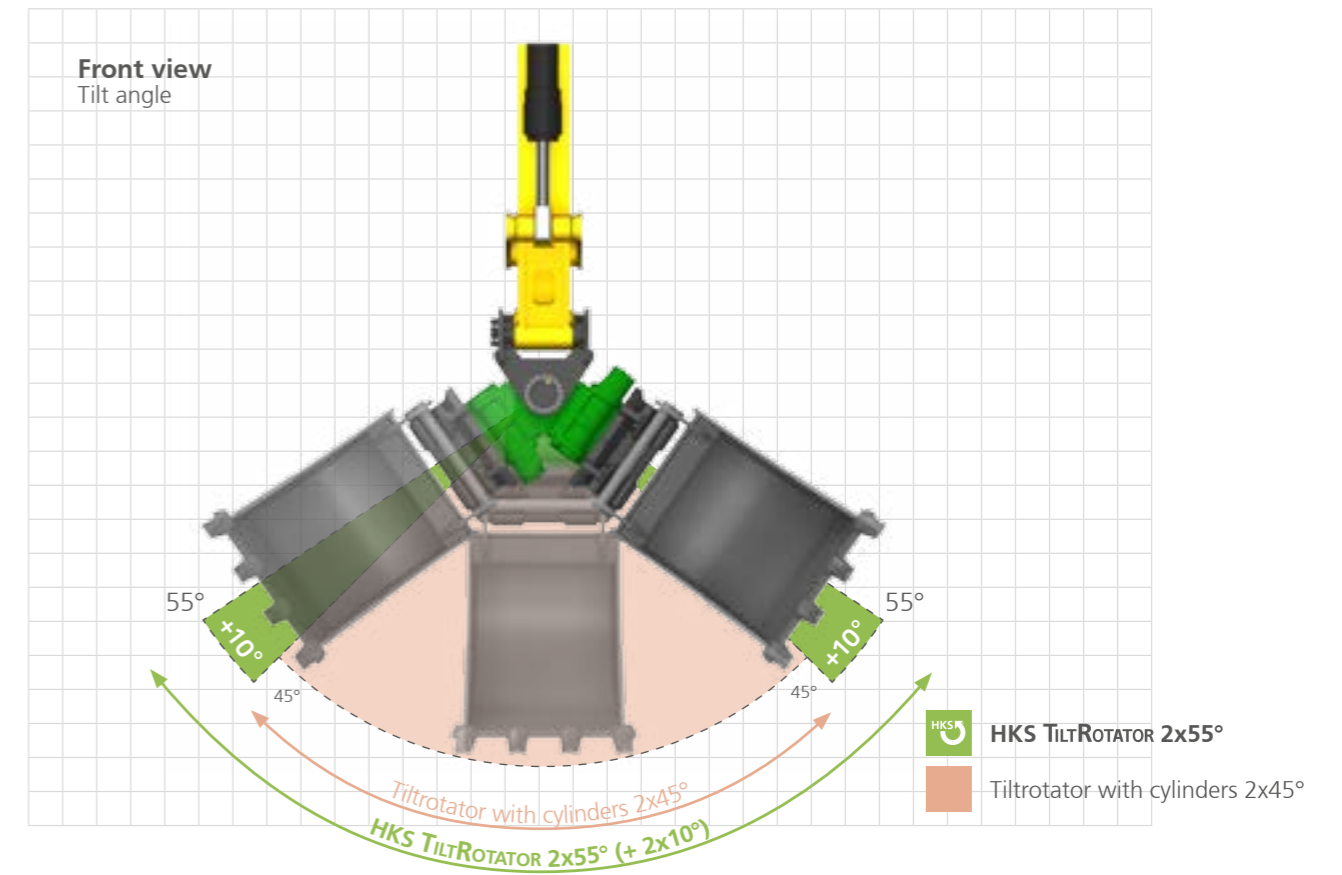

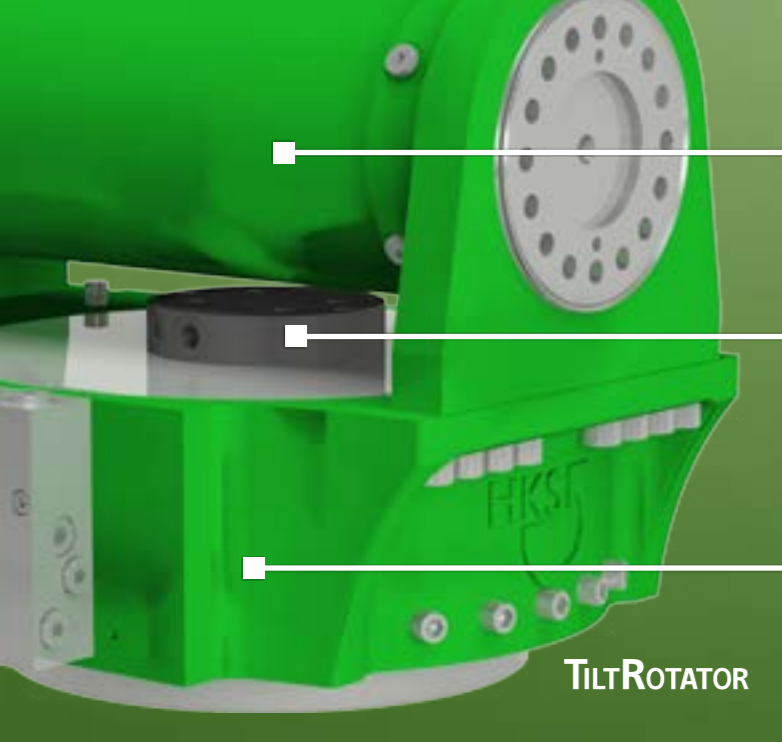

XTRA TILT BVC-R

Oil Feedthrough

RotoBox

TILTROTATOR

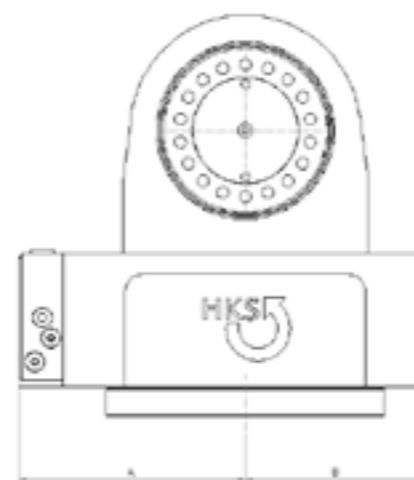

TILTROTATOR	TR 20		TR 35		new TR 60		new TR 90			new TR 120			new TR 150			new TR 200			new TR 270			new TR 400		TR 550
Excavator class (t)	2,0 - 2,5		2,4 - 3,5		3 - 6		5,5 - 9			8 - 12			11 - 15			14 - 20			19 - 27			24 - 33		32 - 55
Oil feedthrough version	-	Standard	-	Standard	-	Standard	-	Standard	XL	-	Standard	XL	-	Standard	XL	-	Standard	XL	-	Standard	XL	on request	on request	
Flow rate of oil feedthrough system at pressure differential $\Delta p = 10$ bar (HLP 46 30 °C)* [l/min]	-	42	-	42	-	52	-	52	130	-	52	130	-	52	160	-	52	160	-	52	200	on request	500	
Allocated RotoBox	RB 30		RB 30		RB 60		RB 120			RB 120			RB 200			RB 200			RB 270			RB 400		RB 550
Weight RotoBox excluding rotary feedthrough [kg]	ab 40		ab 40		ab 78		ab 110			ab 110			ab 159			ab 159			ab 260			on request		on request
Permitted axial load max. [N]	95.000		95.000		100.000		160.000			160.000			210.000			210.000			400.000			on request		on request
Permitted radial load max [N]	48.000		48.000		95.000		140.000			140.000			180.000			180.000			250.000			on request		on request
Torque @ 175 bar [Nm]	810		810		1.350		3.500			3.500			4.700			4.700			8.000			on request		on request
U/min @ l/min at max. 175 bar	8 @ 28 l/min		8 @ 28 l/min		8 @ 28 l/min		8 @ 45 l/min			8 @ 45 l/min			6 @ 45 l/min			6 @ 45 l/min			6 @ 55 l/min			on request		on request
Allocated BVC-R	BVC-R 90		BVC-R 100		BVC-R 110		BVC-R 130			BVC-R 140			BVC-R 140 (more powerful version)			BVC-R 160			BVC-R 200			on request		on request
Tilt angle	110°		110°		110°		110°			110°			110°			110°			110°			on request		on request
Amount of oil required per 6 sec. tilt time	3 l/min		5 l/min		7 l/min		15 l/min			21 l/min			21 l/min			26 l/min			44 l/min			on request		on request
Displacement [dm³]	0,288		0,413		0,63		1,44			2,03			2,08			2,53			4,32			on request		on request
Torque @ 210 bar [Nm]	1.700		2.600		3500		8500			10000			10500			15000			21000			on request		on request
Holding moment @ 210 bar [Nm]	5.000		7.500		11000		20000			22000			28000			38000			52000			on request		on request
Weight [kg]	27		35		58		80			99			122			145			204			on request		on request
Dimensions																						on request		on request
A [mm]	176		176		200		251			251			268			268			292			on request		on request
B [mm]	112		112		145		180			180			215			215			280			on request		on request
F [mm]	193	223	198	228	222	254	264	294	307	266	296	309	296	328	340	305	337	349	333	335	391	on request		on request
G [mm]	263	293	273	303	307	339	378	401	414	378	408	421	415	447	459	441	473	485	476	478	534	on request		on request
L [mm]	301		353		484		480			540			585			585			726			on request		on request
Total weight TR excluding rotary feedthrough [kg]	from 67	from 89	from 75	from 97	from 135	from 171	from 190	from 221	from 262	from 209	from 240	from 280	from 281	from 319	from 390	from 304	from 342	from 410	from 464	from 518	from 654	on request		on request

*) The pressure losses indicated were ascertained in the flow of the rotary feedthrough in one direction. Pressure losses caused by attachments such as screw connections or hoses have not been taken into account. All mentioned weights without quick coupler, permanent shaft connection, adapter flange, cover and screw package.

RotoBox - Work Efficiency

- › Continuous rotating in both directions
- › One RotoBox for all attachments
- › Even more freedom of movement thanks to an extended radius of action
- › Use of narrower working devices made possible by the new, narrower width of the RotoBox

Extend your action radius to 360° with the RotoBox. This enables more flexible operation in a stationary position and additional fields of operation. Hydraulic tools requiring a large amount of oil can also be optimally used with the optional HKS oil feedthrough.

Details

- › Torque of up to 12,000 Nm
- › Up to 8 rotations per minute
- › Operating pressure of up to 175 bar
- › In 7 sizes for a carrier device weight of up to 55 t



Videos from fields of application to find under:
[▶ www.hks-partner.com](https://www.hks-partner.com)

ROTOBOX - New Generation



New generation of the RotoBox

The new generation of the RotoBox is based on a completely new design. The focus was saving on height and weight while maximizing durability. The width has also been enhanced to allow the installation of narrower and therefore lighter attachments.

The two oil feedthrough units with up to 500l/min flow provide even more flexibility. Depending on the application, you can choose amongst our standard version to save weight and fuel, or the XL version of oil feedthrough for the more powerful version.

Your product advantages

- › **Precise operation:** exact maintenance of the selected position, thanks to low-backlash gears and precise holding torques
- › **Great flexibility:** compatible with all quick couplers and carrier devices and with the new narrower width enables to attach narrower working devices.
- › **Faster operation:** thanks to an endlessly rotating 360° action radius, your attachments achieve considerably more operating positions. For instance, by rotating the bucket a backhoe bucket can quickly be turned into a face bucket.
- › **Long service life:** thanks to high-strength steel casting and a worm drive gear filled in grease, downtimes are minimised, and a high utilisation rate of your machine is guaranteed.
- › **Durability:** protection against wear and tear and rust, thanks to special manufacturing methods that give the robust welded housing the utmost accuracy of shape.
- › **Cost savings:** no additional rotator required for hydraulic tools.

Your product advantages in details

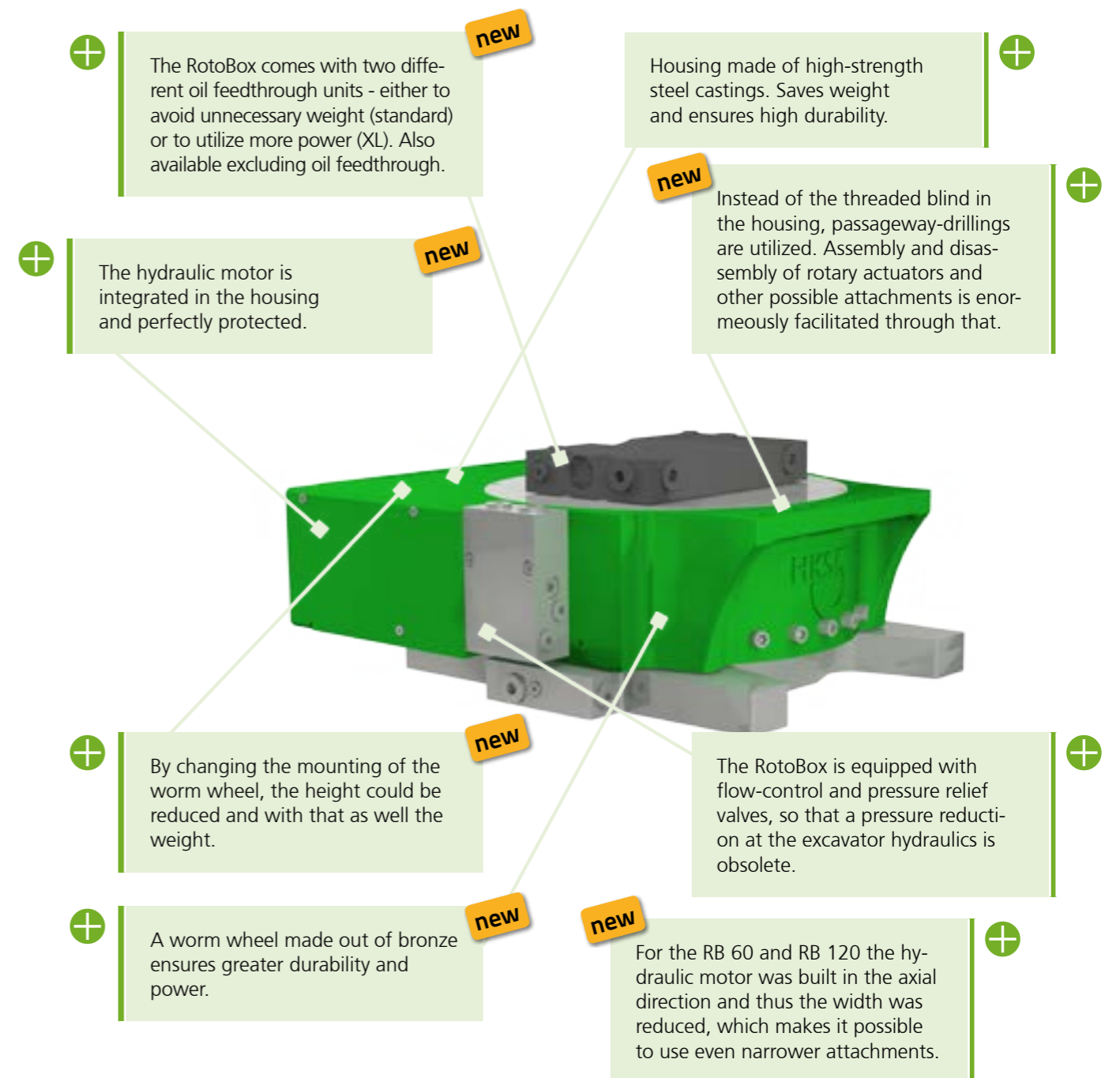

Optimized Design - Powerful Technics

Our experienced staff will gladly help you select the right rotary drive. Contact us at:
 ▶ +49 6053 6163-0

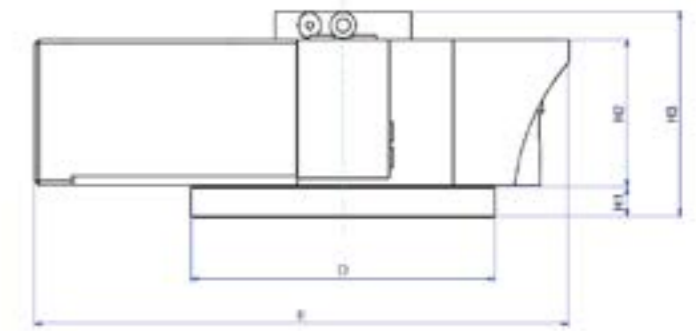
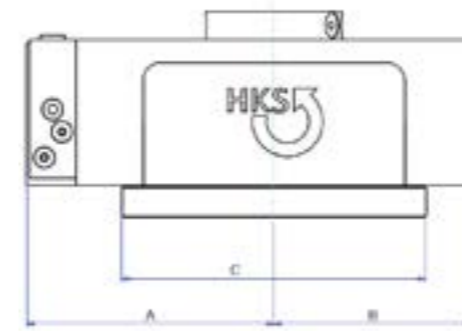

RotoBox	RB 30		new RB 60		new RB 120		new RB 200		new RB 270		new RB 400		RB 550		
Excavator class (t)	1 - 3,5		3 - 6		5 - 12		11 - 20		19 - 27		26 - 33		32 - 55		
Oil feedthrough version	- Standard		- Standard		- Standard XL		- Standard XL		- Standard XL		- Standard XL				
Flow rate of oil feedthrough system at pressure difference $\Delta p = 10$ bar (HLP 46 30 °C)*	-	42 [l/min]	-	52 [l/min]	-	52 [l/min]	130 [l/min]	-	52 [l/min]	160 [l/min]	-	52 [l/min]	200 [l/min]	on request	500 [l/min]
Weight of RotoBox excluding rotary feedthrough [kg]	from 40		from 78		from 110		from 159		from 260		on request		~800		
Permitted axial load max. [N]	95.000		100.000		160.000		210.000		400.000		on request		850.000		
Permitted radial load max [N]	48.000		95.000		140.000		180.000		250.000		on request		500.000		
Torque @ 175 bar [Nm]	810		1.350		3.500		4.700		8.000		on request		12.000		
U/min @ l/min at max. 175 bar	8 @ 28 l/min		8 @ 28 l/min		8 @ 45 l/min		6 @ 45 l/min		6 @ 55 l/min		on request		5 @ 82 l/min		

Dimensions														
A [mm]	176		200		251		268		292		on request		355	
B [mm]	112		145		180		215		280		on request		300	
C [mm]	255		290		265 400		330 490		380 600		on request		880	
D [mm]	290		275		265 360		330 490		380 500		on request		600	
E [mm]	425		481		530		580 580		721		on request		320	
H1 [mm]	30		32		30 43		32 44		2 56		on request		400	
H2 [mm]	106		129		151		165		185		on request		400	
H3 [mm]	146	172	188	198	201	206	231	197	222	251	187	212	290	-

*) The pressure losses indicated were ascertained in the flow of the rotary feedthrough in one direction. Pressure losses caused by attachments such as screw connections or hoses have not been taken into account. All mentioned weights without quick coupler, permanent shaft connection, adapter flange, cover and screw package.

500 l/min

Maximum in Performance



HKS OIL FEEDTHROUGH

Details

- › 2 versions eligible (standard + XL)
- › 5 channels with up to 500l/min
- › Optional power rotary feedthrough
- › Up to 350 bar operating pressure

With the extra large HKS oil feedthrough, connected hydraulic tools are supplied with a flow rate of up to 500l/min oil (pressure difference $\Delta p = 10$ bar, (HLP 46 30 °C)).

Only the HKS oil feedthrough can get the flow rate supplied by your carrier device to your attachment at the lowest pressure difference. This feature enables your tools to operate at full capacity. Don't make compromises – put your trust in HKS products.

The unique design and special manufacturing process allow for particularly large channels for greater passage and a low efficiency loss rate. The individual flow rates can be flexibly distributed using multiple connectors. The piping can therefore be optimally adjusted and implemented to suit your carrier device

With 5 oil channels available (2 for quick coupler, 2 for work unit, 1 for drain line) and a current power rotary feedthrough.

Special solutions for 3, 6 or 7 channels and more on request!

Product advantages

- › Maximum capacity for your hydraulic attachments
- › Wear-resistant, high-quality components
- › Your attachment has an operating pressure of up to 350 bar
- › Up to 500 l/min flow rate and extremely low pressure differential
- › Optimum adjustment to any quick coupler
- › Electric feedthrough with up to 12 connections of 2 amperes each
- › Available for the excavator class of 5-27t optional with standard version or extra large (XL) oil rotary feedthrough

Standard oil feedthrough



- › WEIGHT SAVING!
- › Low weight with extremely effective delivery of up to 52 l/min
- › Compatible with the new RotoBox
- › Already available for mini-excavators as from 1t
- › Minimum back pressure with viscous hydraulic oil HLP 46 at 30 °C

Oil feedthrough for RotoBox	RB 30	new RB 60	new RB 120	new RB 200	new RB 270
Excavator class (t)	1 - 3,5	3 - 6	5 - 12	11 - 20	19 - 27
Weight [kg]	7,5	13	10,5	10,5	10,5
Flow rate of oil feedthrough system at pressure difference $\Delta p = 10$ bar (HLP 46 30 °C)*	42 [l/min]	52 [l/min]	52 [l/min]	52 [l/min]	52 [l/min]

XtraLarge oil feedthrough (XL)



- › Compatible with the new RotoBox
- › Incredible delivery for powerful work assignments available from excavators as from 5t
- › Minimum back pressure with viscous hydraulic oil HLP 46 at 30 °C

Oil feedthrough for RotoBox	new RB 120	new RB 200	new RB 270	new RB 400	RB 550
Excavator class (t)	5 - 12	11 - 20	19 - 27	26 - 33	32 - 55
Weight [kg]	22,9	35,5	57,2	auf Anfrage	245
Flow rate of oil feedthrough system at pressure difference $\Delta p = 10$ bar (HLP 46 30 °C)*	130 [l/min]	160 [l/min]	200 [l/min]	auf Anfrage	500 [l/min]

*) The pressure losses indicated were ascertained in the flow of the rotary feedthrough in one direction. Pressure losses caused by attachments such as screw connections or hoses have not been taken into account. All mentioned weights are excluding adapter flange, cover and screw package.



XTRATILT - Maintenance-free in every version

- › Tilt up to 2 x 90°
- › One **XTRATILT** for all attachments
- › An additional movement axis for greater versatility and flexibility

Many years of experience and innovation have made the XtraTilt even more robust, reliable and durable. Thanks to the special deflectors on both sides, dirt is prevented from entering the housing of the XtraTilt range, making it maintenance-free from the day it leaves the factory. This feature considerably reduces maintenance costs.

Details

- › Standard rotating angles: 100°/140°/180°
- › Holding torque of up to 165,000 Nm
- › Operating pressure of up to 250 bar
- › 54 models for 18 sizes for a carrier device weight of up to 100 t
- › Further tilting weights available upon request

Videos from fields of application to find under:
www.hks-partner.com



Advancement by longevity

Your product advantages

- › **Maintenance-free operation**, since there is no need for re-lubrication and readjustment.
- › **Unlimited flexibility**: compatible with all quick couplers and carrier devices.
- › **Less material excavation**: narrower attachment tools can be used, considerably reducing the working width.
- › **More precise operation**: high holding torques and precise manufacture ensure the exact maintenance of the selected position.
- › **Constant torque/holding torque**: regardless of the operating angle.
- › **Durability**: protection against wear, tear and rust thanks to special manufacturing, annealing and hardening processes which give the robust welded housings the utmost accuracy of shape.

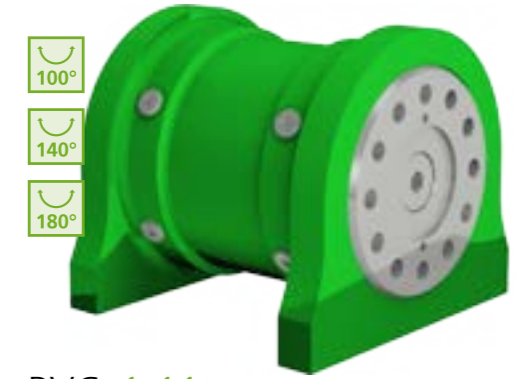

BVC 1-11t

- › Long-term quality in the use of tilt buckets for excavator classes up to 11 t.
- › Available tilt angles of 100°, 140° and 180°

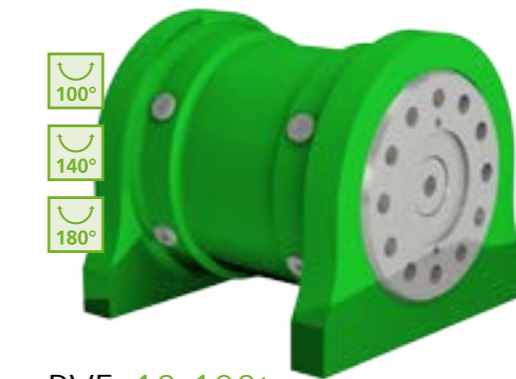

BVE 10-100t

- › Operating pressure of up to 250 bar
(alternative: 190 bar for tilt angle of 100°)
- › Designed for biologically degradable media (dual seals)
- › Reinforced shaft



BVD 1-10t

Compared to the BVC at the same output:

- › Lower space requirement
- › Ideal fit for all commercially available quick couplers
- › Regardless of the excavator hydraulics, thanks to directly connected load-holding valve
- › Only available with a tilt angle of 180°

Important Differences in Detail

Built for harsh everyday applications

The compact 4-part construction of high quality materials and precise manufacturing make the XtraTilt to the most robust rotary drive of its class.

Built for Long-Term Use

— Bucket with linear cylinder

- Only suitable for trench buckets
- Damage to the cylinders caused by soil, stones and dirt
- Continuous re-lubrication and greasing of the cylinder bearing necessary
- Tilt head with bearing surfaces requiring lubrication, time-consuming assembly
- Over time, worn-out connection elements must be replaced

Minimum working width

x

Simplified representation

HKS XTRA TILT BETTER WITHOUT CYLINDER +

- Durable, robust, protected, powerful
- Greater accessibility thanks to greater tilt angle
- The lack of maintenance saves servicing costs
- Compact – fits all buckets and tools

Minimum working width

$\sim \frac{x}{3}$

+ End flange with friction bearings, fastening thread and special deflector on both sides

+ Shaft with mounting flange and friction bearings all in one

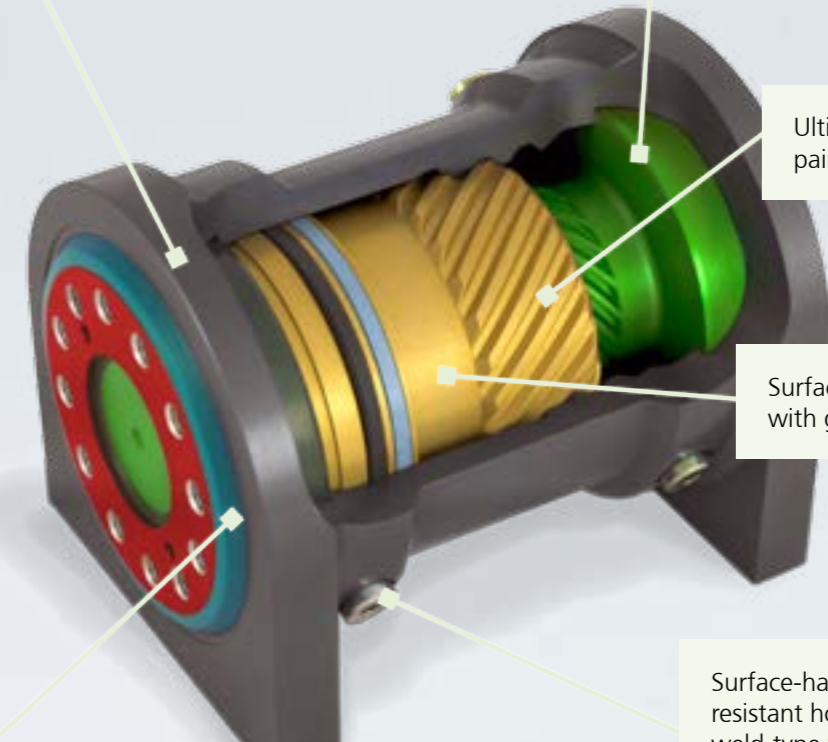

+ Ultimate precision manufacture of paired interleaving

+ Surface-hardened piston with guiding element

+ Actuator centring on both sides for optimum power distribution

+ Surface-hardened and corrosion-resistant housing with screw or weld-type fastening on the feet

Convincing Performance

Our experienced staff will gladly help you select the right rotary drive. Contact us at: ▶ +49 6053 6163-0

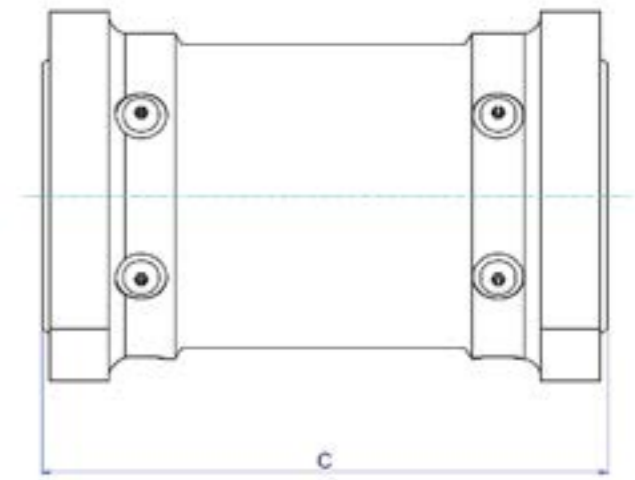
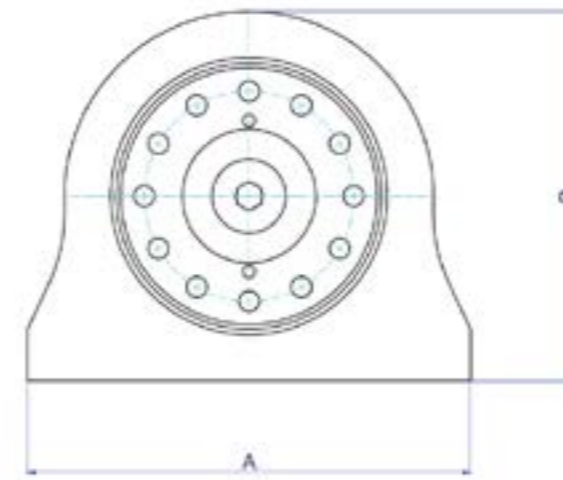

XTRATILT Size	100			115			125*		130			140*			160			180			
Excavator class (t)	< 1,8			1,8-3,8			3-5,5		4-6,8			5-7,5			7-9			8,5-11			
XTRATILT BV-Series	C	F ¹		C	D	F ¹	C	D	C	D	F ¹	C	C	D	F ¹	C					
Holding torque [Nm]	2.480	2.400		4.300	4.300	6.400	7.800	8.200	10.000	on request	12.800	10.900	17.500	17.500	20.000	19.500					
Operating pressure [bar]	190	210		190	210	210	190	210	190	on request	210	190	190	210	210	190					
Tilt angle	100°	140°	180°	100°	140°	180°	178°	180°	100°	140°	180°	100°	140°	180°	178°	100°	140°	180°	178°	180°	
Displacement [dm³]	0,18	0,25	0,323	0,284	0,399	0,513	0,527	0,617	0,385	0,538	0,693	0,84	0,58	0,813	1,045	1,06	1,062	0,696	0,974	1,253	
Weight [kg]	19	21	22	48	42	47	52	43	38	51	57	62	61	59	64	70	88	112	85	94	103
A [mm]	150	190		220	220	190	220	224	270	300	280	300	300	290	284	332					
B [mm]	152	233		187	192	208	212	232	266	266	250	266	273	273	373	290					
C [mm]	197	221	245	281	264	306	344	275	259	267	305	345	275	267	305	345	275	398	291	337	383

F¹) Weight and dimensions are including lugs.

	225*	240	250	260	270	290	300	350	400*	420*	450*
Excavator class (t)	10-13	10-16	15-23	22-26	25-29	28-34	28-38	37-50	48-60	58-70	68-100
XTRATILT BV-Series	E	E	F ¹	E	F ¹	E	E	E	E	E	E
Holding torque [Nm]	36.700	40.000	34.000	47.300	40.000	53.000	63.000	80.000	90.000	100.000	140.000
Operating pressure [bar]	250	250	210	250	210	250	250	250	on request	on request	250
Tilt angle	100°	140°	180°	100°	140°	180°	100°	140°	180°	100°	140°
Displacement [dm³]	1,498	2,098	3,0	1,851	2,591	3,331	2,97	1,777	2,486	3,197	3,02
Weight [kg]	166	188	207	182	186	206	269	202	236	264	321
A [mm]	390	390	400	412	410	450	492	490	on request	on request	570
B [mm]	327	328	370	353	387	380	400	400	on request	on request	478
C [mm]	350	404	455	354	412	470	510	368	430	492	538

Further sizes and tilt angles available on request ▶ vertrieb@hks-partner.com

All weights exclude quick coupler and adapter to dipperstick connection.

*) Manufacture on request

on request

Sandwich - the solution

The HKS sandwich solution enables an HKS TiltRotator to be equipped with a quick coupler instead of a fixed adapter to dipperstick connection, for instance, which means that the excavator driver can use the HKS TiltRotator like a standard attachment. The lower quick coupler is still responsible for the change-over of attachments.

FLEET MANAGEMENT. The HKS product can be used for your entire fleet.

ATTACHMENTS. Existing attachments can still be used without the need for conversion. At the same time, all attachments can be combined with the HKS product for all carrier devices.

INDEPENDENCE. The carrier device can still be operated by untrained personnel with no TiltRotator/RotoBox/XtraTilt experience.

NO TEAR-OUT FORCE LOSSES. The HKS product can be removed if necessary, and the carrier device works at full power upon start-up.

WEIGHT REDUCTION. Should the lifting load be too high for the carrier device, the HKS product can be removed for this extreme application.

QUICK COUPLER. Both mechanical and fully hydraulic quick-coupler systems can be used and combined. At the same time, it is also possible to use two different systems. The permanently pressurised locking mechanism complies with EU machinery directives.

Modular „TILTROTATOR“

Along with an HKS RotoBox or HKS XtraTilt in a sandwich design, you have combined a flexible, modular TiltRotator.

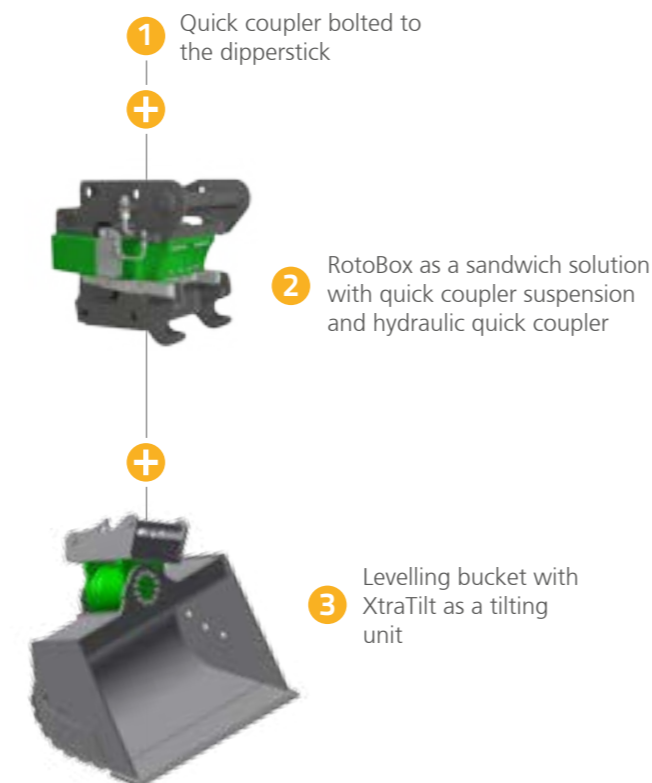
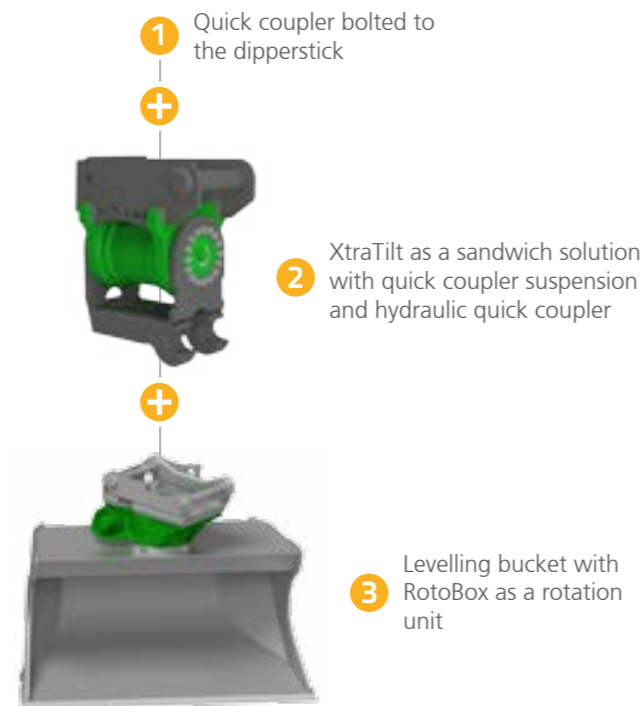

Flexibly replaceable

Here are some examples of how the sandwich solution allows you to work flexibly. You can use the right tool for the work at hand, at any time. As a combination with or without HKS products.

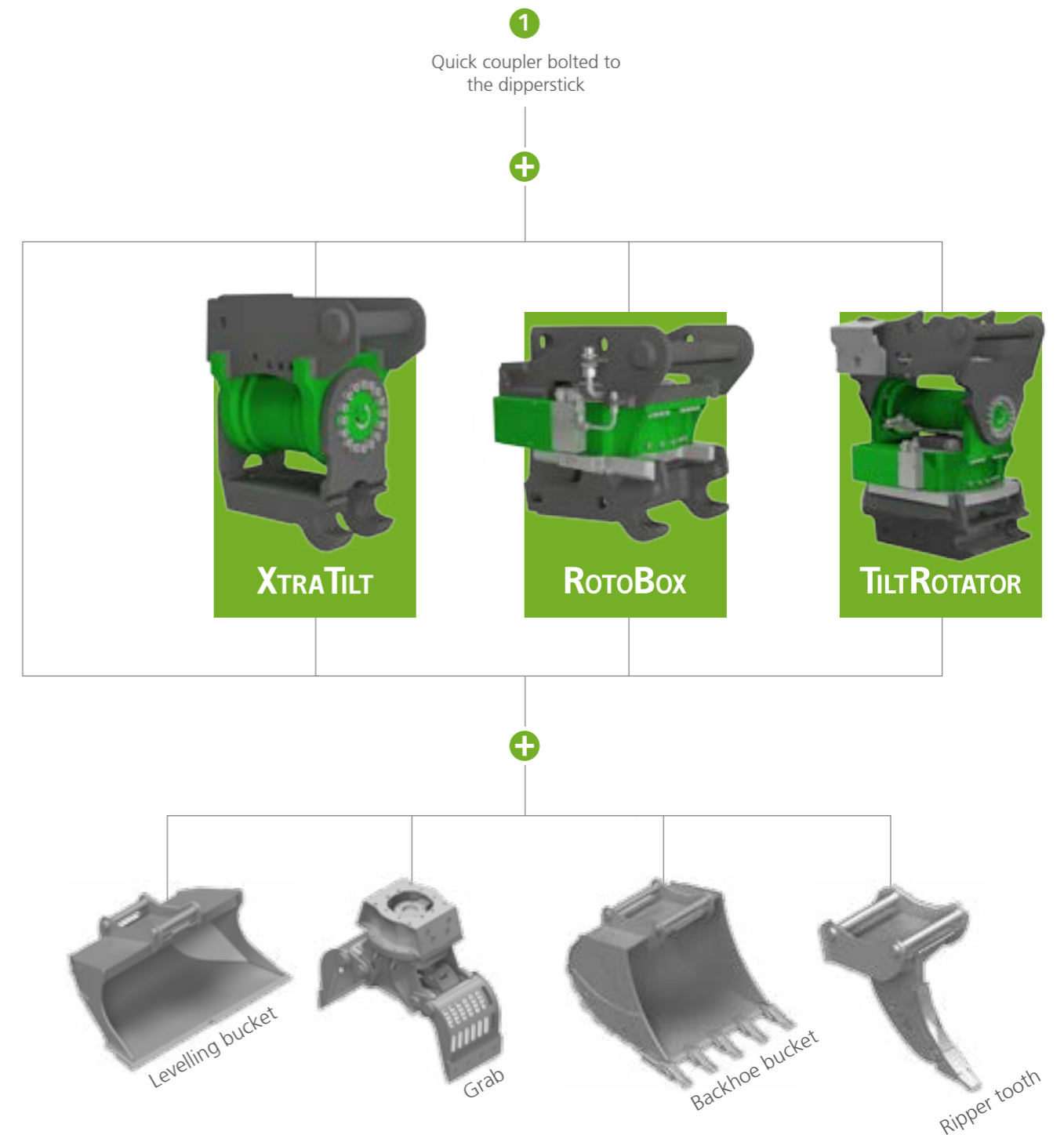

Control - simply implemented

Precision engineering also requires precision control. HKS therefore offers a high-performance electrical control unit for its products to provide optimum support for the functions of the TiltRotator. Using the HKS control system you can tilt and rotate your attachments – if re-quired all at the same time and at the touch of a button.

Our developers have also ensured maximum system flexibility for the HKS control system.

Control system models

BTS 01: Control system

BTS 02: External 6/2 way valve

Your options

- › The control unit and cable set can easily be installed without the need to interfere with the on-board electrics: however, they can also be incorporated in the existing electrical system by a specialist workshop if required
- › The control system makes use of the existing hydraulic installation of the basic machine
- › Suitable for all hydraulic excavators with an on-board voltage of 12–24 V

	BTS 01	BTS 02
Tilting, rotating and extra function, all simultaneously	• 2	-
Tilting + rotating simultaneously, switching between tilting + extra function	-	• 2
Switching between tilting + rotating, extra function also simultaneously	-	• 2
Tilting + rotating simultaneously, without extra function	• 1	-
Switching between tilting + rotating, without extra function	-	• 1

Legend:

•	Useable HKS control system
2	Number of required control circuits on excavator

TILTROTATOR



The optimally designed control system enables you to work with your TiltRotator as if it were an extension of your arm.

Prop valve block

Valve block with proportional valves for precise control of the TiltRotator. Can be installed in the upper structure or on the tilt rotator!



Trigger valve



For the pilot control of a control circuit

JoyDapter



The HKS JoyDapter turns a standard joystick into a proportional joystick without having to interfere with the machine control system. Fast installation, safe operation.

Cable set



Electrical cable set, including plug and switch for establishing the connection between valves and control unit.

Control unit



Polarised connecting plug and solid design guarantee quick and easy fitting of the control unit. The robust plastic housing protects against dirt and moisture and is also short-circuit-proof.

Additional features:

- › Up to 16 users can be programmed
- › Large function display
- › All common proportional joysticks can be read in
- › Software updates can be programmed via CAN bus



Our Service - spot and fast



You can steadily rely on getting a quality product with HKS. We have also set a target to implement the possible functions for the daily use of your machine.

If you need even on site support, our Service-Team helps personally and fast - even on site. We offer this service anywhere in within Germany.

Since every HKS product is individually designed and manufactured for you, we know exactly which components are installed. Should you require support for one of our products, we can immediately provide assistance and replace parts quickly.

Our sales and service team appreciates to advise you with any challenge you experience.

During the winter months we offer regular maintenance. We - as your manufacturer - offer for example a complete maintenance and wear parts replacement, to ensure a smooth utilisation of your excavator.

We put great importance to the fact that you are satisfied with our products.

Meet our team of experts!

service@hks-partner.com ▶ +49 6053 6163-0

Learn from the Experts!



In order to experience the HKS Construction Technology „in action“, we regularly present our products at national and international construction machinery trade shows.

At the trade shows, we present our products with various buckets and numerous other attachments (e.g. stone mills, compressor plates, hammers, grabs, etc.).

In addition to the trade shows, you can always make an appointment to test-drive an excavator on our demonstration premises on site.

We look forward to your visit!

Equipment for in-house exhibitions and demonstrations available on request.

▶ demopark@hks-partner.com

The following excavators and tools are at your disposal on site

TILTROTATOR • ROTOBOX • XTRATILT
8t excavator • 10t excavator • 12t excavator

Grave space spoon	Hammer
Small bucket	Grab
Compressor	Milling machine



State-of-the-art German mechanical engineering – products for the whole world „Made in Germany“

The HKS Group is a family-run company that operates throughout the world. Spread over three production sites in Germany, it employs over 190 staff, with a large number of sales partners all over the world and an export share of 60 percent.

Founded in 1970, the mechanical engineering company produces hydraulic rotary actuators for industry, vehicle construction, mining, mobile hydraulics and marine technology. The latest product development has been designed specifically for construction machine technology.

The third generation has been involved in managing this family-run company for more than four years, bringing innovation, flexibility and passion into the Group.

With longtime experience in design and development under its belt, the company's core competencies also include customer-specific developments, making HKS products among the very best in the industry.

HKS develops, designs and produces to the highest level to meet your demands, without exception. Customers throughout the world depend on the extremely reliable products, and as a result we are the world's market leader in our field.

Through an innovative product policy and continuous expansion of our radius of action the HKS Group has for years recorded sound, stable growth.





HKS CONSTRUCTION TECHNOLOGY

TILTROTATOR • ROTOBOX • XTRATILT

www.hks-partner.com



Scan me 

-  facebook.com/HKSDrehAntriebe
-  twitter.com/HKSDrehAntriebe
-  youtube.com/HKSDrehAntriebe
-  issuu.com/hks_

Your partner

HKS Dreh-Antriebe GmbH® • Leipziger Straße 55 • 63607 Wächtersbach-Aufenau • Germany • fon: +49 6053 6163-0 • fax: +49 6053 6163-639

Copyright 2016 HKS Dreh-Antriebe GmbH®
DIN EN ISO 9001:2008 TÜV certified
Illustrations are approximations. No guarantee
for the information provided.
Subject to changes.
Version dated: 07/2016

